

# Gleichstrommotor Baureihe M 63

# DC-Motor Type M 63



## Merkmale

Gleichstrommotor mit Permanentmagnet  
Grafit-Kupfer-Bürsten  
Gehäuse verzinkt und chromatiert  
Kugellager  
Befestigungsbild nach DIN 42016  
Isolierstoffklasse E (VDE 0530)  
Funkentstörung möglich

## Specification

D.C. permanent magnet motor  
Graphit-copper brushes  
Motor housing zinc plated and chromized  
Ball bearings  
Mounting holes to DIN standard 42016  
Insulation class E (VDE 0530)  
RFI-suppression feasible

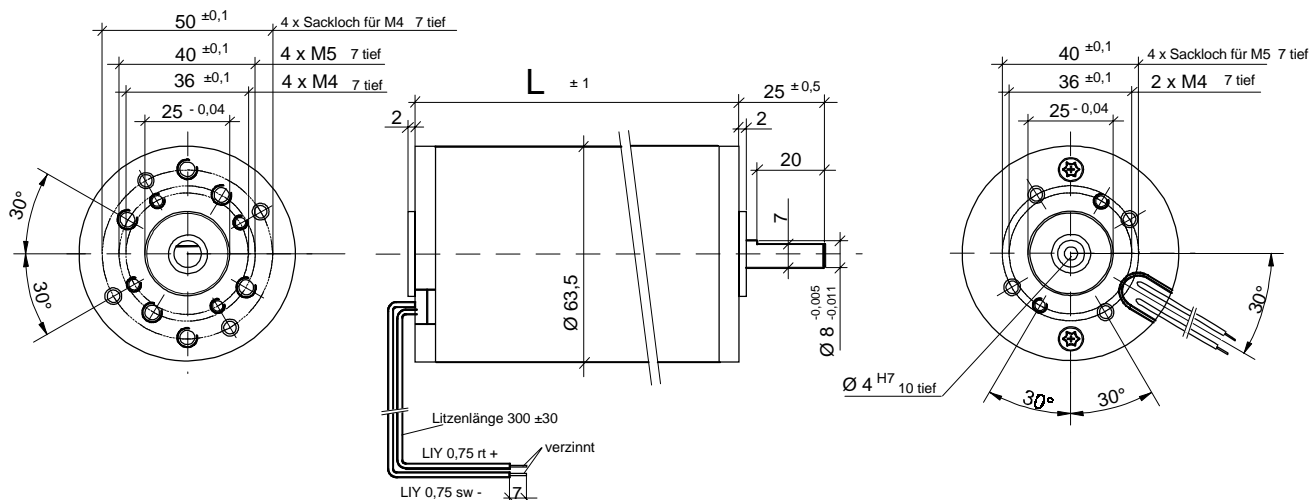

## Leistungsdaten / Performance

			M63x25/l L = 95 mm	M63x40/l L = 110 mm	M63x60/l L = 130 mm
Spannungsbereich	/ Voltage range	V	12 - 42		
Drehzahlbereich	/ Speed range	rpm	1500 - 12000		
Dauerdrehmoment	/ Continuous torque	Ncm	14	18	30
Massenträgheitsmoment	/ Inertia	gcm <sup>2</sup>	596	792	1209
Mechanische Zeitkonstante	/ Mechanical time constant	ms	16,7	13	11,8
Gewicht	/ Weight	kg	1,16	1,46	1,73
Lebensdauer ca. je nach Betriebsbedingungen	/ Life-approx. depends on operating conditions	h	3000		
Zulässige Achsbelastung	Kugellager ( Ausführung l ) * Ball bearings ( design l ) *	axial	N	110	
		radial	N	300	
Permissible shaft loads		axial	N	110	
		radial	N	300	

\*) bei 3000 U/min und 3000 h nominelle Lebensdauer, gleichzeitige axiale und radiale Belastung

\*) at 3000 rpm and 3000 hrs nominal life, simultaneous axial and radial loads

## Lagerausführungen / Standard types

Typ	Bestell.-Nr.	Abgabeleistung [W]	Nennspannung [V]	Nenn-drehzahl [1/min]	Nenn-drehmoment [Ncm]	Nenn-strom [A]	Drehzahl-konstante [1/min/Ncm]	Drehmoment-konstante [Ncm/A]
Type	Part no.	Output power [W]	Nom. voltage [V]	Nom. speed [rpm]	Nom. torque [Ncm]	Nom. current [A]	Speed constant [rpm/Ncm]	Torque constant [Ncm/A]
M63x25/l	210961	51	24	3500	14	3,3	39,5	4,2
M63x25/l	210950	48	12	3300	14	5,95	39,3	2,8
M63x40/l	210962	56	24	3000	18	3,45	20,5	5,2
M63x40/l	210951	48	12	2550	18	5,35	19,4	3,8
M63x60/l	220311	96	12	3050	30	10,4	12,5	3,2
M63x60/l	210963	94	24	3000	30	5,5	13,9	5,4

Änderungen vorbehalten  
Right of alteration without prior notice reserve

Belastungskennlinie / Characteristic M63x25/I

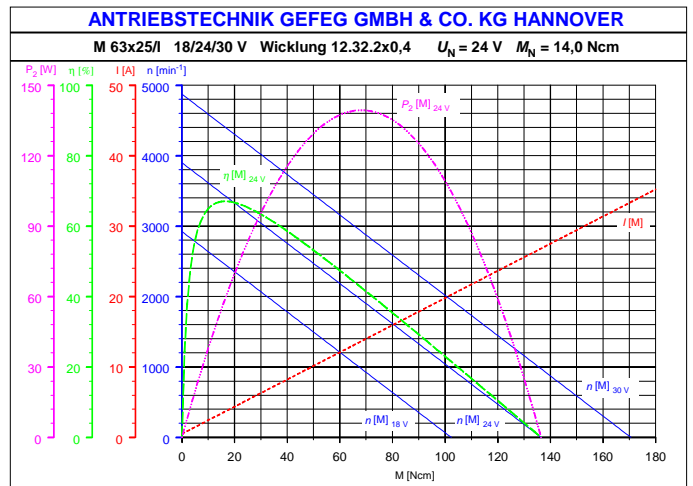
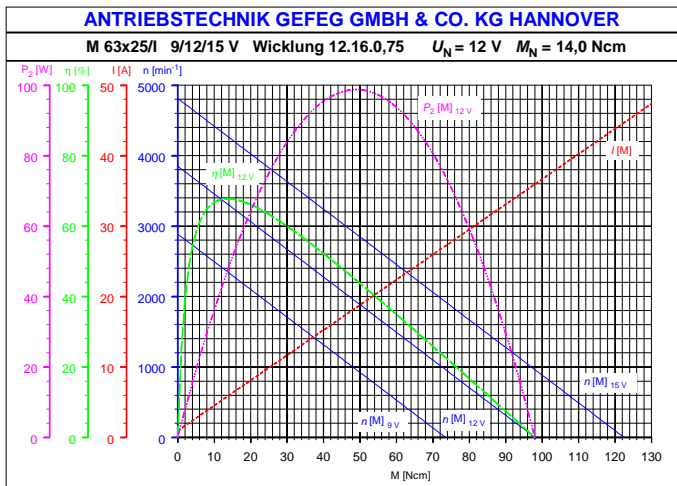

Belastungskennlinie / Characteristic M63x40/I

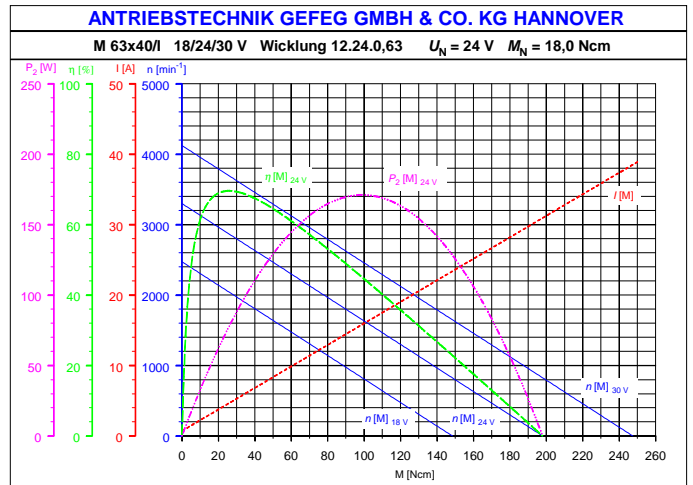
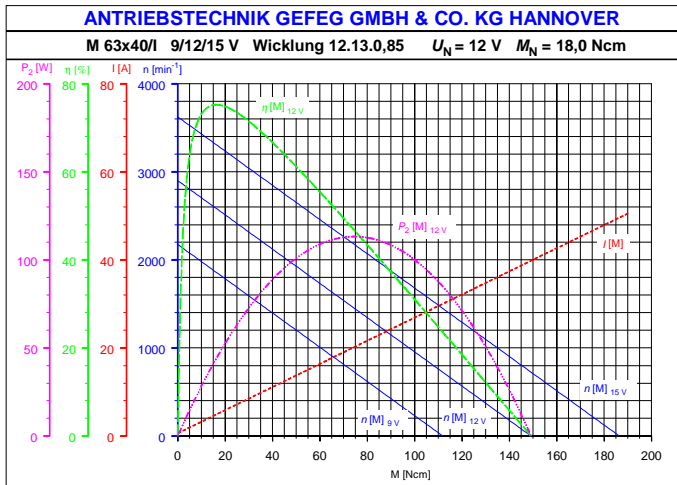

Belastungskennlinie / Characteristic M63x60/I

